

Demo 10701: Damped Oscillator on an Air Track

2 Damped and Driven Harmonic Oscillation

Question 1: How to deal with periodic driving force which are not sinusoidal functions?

Answer: Any reasonably continuous periodic function with period L can be expressed as an infinite sum of sines and cosines

$$f(x) = \frac{a_0}{2} + \sum_{n=1}^{\infty} \left(a_n \cos\left(\frac{2\pi nx}{L}\right) + b_n \sin\left(\frac{2\pi nx}{L}\right) \right) \quad (1)$$

As the sin and cos functions are orthonormal in the following way

$$\begin{aligned} \int_0^L dx \sin\left(\frac{2\pi nx}{L}\right) \sin\left(\frac{2\pi n'x}{L}\right) &= \frac{L}{2} \delta_{nn'} \\ \int_0^L dx \cos\left(\frac{2\pi nx}{L}\right) \cos\left(\frac{2\pi n'x}{L}\right) &= \frac{L}{2} \delta_{nn'} \\ \int_0^L dx \sin\left(\frac{2\pi nx}{L}\right) \cos\left(\frac{2\pi n'x}{L}\right) &= 0 \end{aligned} \quad (2)$$

The coefficients a_n and b_n can be found from

$$\begin{aligned} a_n &= \frac{2}{L} \int_0^L dx f(x) \cos\left(\frac{2\pi nx}{L}\right) \\ b_n &= \frac{2}{L} \int_0^L dx f(x) \sin\left(\frac{2\pi nx}{L}\right) \end{aligned} \quad (3)$$

Hence, given a driving force of the form $f(t)$, we can decompose it into all the sin and cos components, solve the driven motion for each component and then add everything together to obtain the total motion.

Question 2: So we found one solution, which is good, but how to set initial conditions?

Answer: In the steady state solution, we don't have any free parameter to change in order to accommodate different initial conditions. In fact, this is not the only solution, there are many others. If $x_D(t)$ is a solution to the inhomogeneous equation

$$\frac{d^2}{dt^2}x(t) + \Gamma \frac{d}{dt}x(t) + \omega_0^2 x(t) = \frac{F_0}{m} \cos(\omega_D t) \quad (4)$$

and if $x_0(t)$ is a solution to the homogeneous equation

$$\frac{d^2}{dt^2}x(t) + \Gamma \frac{d}{dt}x(t) + \omega_0^2 x(t) = 0 \quad (5)$$

then $x_D(t) + x_0(t)$ is also a solution of the inhomogeneous equation, describing the driven, damped oscillation.

While $x_D(t)$ describes the periodic driven oscillation at frequency ω_D , $x_0(t)$ describes the decaying oscillation at frequency $\sqrt{\omega_0^2 - \Gamma^2/4}$. It decays away after time on the order of $\frac{1}{\Gamma}$ and is called a

transient. It is involved to match any given initial condition, but disappears after a while and does not affect the steady state of the system at long times. The steady state is completely determined by the driven part, including its frequency, amplitude and the relative phase with the driving force.

Question 3: how to formulate a driven RLC circuit as a driven harmonic oscillator?

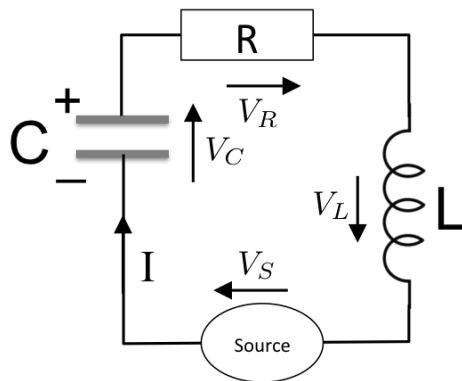

Add to the LC circuit a finite resistance R and a periodic driving source S , so that it becomes a driven damped oscillator. To establish the equation of motion, we choose the degree of freedom to be the current $I(t)$ in the circuit, and choose a direction for the current and the voltage across all elements as shown in the figure. The EOM is then given by

$$0 = V_S + V_L + V_C + V_R = V_S - L \frac{dI}{dt} + \frac{Q}{C} - RI \quad (6)$$

Taking the time derivative on both sides of this equation, we get

$$0 = \frac{d}{dt} V_S - L \frac{d^2 I}{dt^2} - \frac{I}{C} - R \frac{dI}{dt} \quad (7)$$

which can be reorganized into

$$\frac{d^2 I}{dt^2} + \frac{R}{L} \frac{dI}{dt} + \frac{1}{LC} I = \frac{1}{L} \frac{d}{dt} V_S \quad (8)$$

From this equation, we can see that the intrinsic frequency is given by $\omega_0 = \sqrt{\frac{1}{LC}}$, while the friction constant is given by $\Gamma = \frac{R}{L}$.

Demo: LRC circuit

3 Coupled Harmonic Oscillators, Normal Modes

3.1 Two masses coupled by spring

Demo 20301: Two Coupled Air Track Gliders

Having studied the oscillation of a single degree of freedom in detail, now let's move on to the discussion of the oscillation of several coupled degrees of freedom. As the simplest example, consider two blocks as arranged in the following figure.

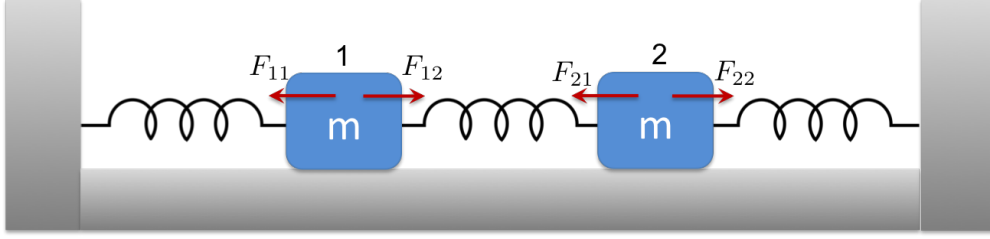

Suppose that the two blocks are of the same mass m , the three springs have the same Hooke's constant k . Initially, all three springs are relaxed and the two masses are at equilibrium position x_{10} and x_{20} . Assume no friction or external driving force. If we offset the two masses to a non-equilibrium position, the system is going to start to oscillate and the oscillation of the two masses are going to be coupled. To understand this coupled oscillation, let's write down the EOM.

For mass 1, the EOM is

$$m \frac{d^2 x_1}{dt^2} = -k(x_1 - x_{10}) + k[(x_2 - x_{20}) - (x_1 - x_{10})] \quad (9)$$

For mass 2, the EOM is

$$m \frac{d^2 x_2}{dt^2} = -k(x_2 - x_{20}) - k[(x_2 - x_{20}) - (x_1 - x_{10})] \quad (10)$$

Let's change variables to $\tilde{x}_1 = x_1 - x_{10}$, $\tilde{x}_2 = x_2 - x_{20}$ and write everything in matrix form

$$X = \begin{pmatrix} \tilde{x}_1 \\ \tilde{x}_2 \end{pmatrix}, \quad M = \begin{pmatrix} m & 0 \\ 0 & m \end{pmatrix}, \quad K = \begin{pmatrix} 2k & -k \\ -k & 2k \end{pmatrix} \quad (11)$$

and the EOM becomes

$$M \frac{d^2 X}{dt^2} = -KX \quad (12)$$

which looks very close in form to the EOM for a single mass on a spring, but we should keep in mind that everything is now a matrix. Moving M to the right hand side of the equation (by taking a matrix inverse), we get

$$\frac{d^2 X}{dt^2} = -M^{-1}KX = - \begin{pmatrix} 2k/m & -k/m \\ -k/m & 2k/m \end{pmatrix} X \quad (13)$$

To solve this set of equation, we put it again into complex form

$$\frac{d^2 Z}{dt^2} = -M^{-1}KZ \quad (14)$$

where Z is a two component complex vector. Suppose that $Z(t)$ takes the form of $Z(t) = Ae^{-i\omega t}$, where A is a vector $\begin{pmatrix} A_1 \\ A_2 \end{pmatrix}$ of complex numbers that is independent of time. Substituting this form of solution into the EOM, we get

$$\frac{d^2 Z}{dt^2} = -\omega^2 Ae^{-i\omega t} = -M^{-1}KAe^{-i\omega t} \quad (15)$$

Note that while we can cancel the two $e^{-i\omega t}$ factors on the two sides, we cannot cancel the two A s because they are vectors. The EOM becomes

$$M^{-1}KA = \omega^2 A \quad (16)$$

which is the eigen-equation of $M^{-1}K$ with eigenvector A and eigenvalue ω^2 .